

**L550**  
**Tabletop Low Speed Centrifuge**

**Instruction Manual**

**(Read the Instruction Carefully Before Operation)**

<b>Index.....</b>	<b>Page</b>
<b>1、 Attention for safety.....</b>	<b>2</b>
<b>1.1 Attention for installation and maintenance .....</b>	<b>2</b>
<b>1.2 Attention for electric system.....</b>	<b>2</b>
<b>1.3 Attention for fireproofing .....</b>	<b>2</b>
<b>1.4 Attention for safe operation .....</b>	<b>3</b>
<b>1.5 Attention for safety in chemistry and biology .....</b>	<b>3</b>
<b>2、 Symbols and meanings.....</b>	<b>4</b>
<b>3、 Application and scope.....</b>	<b>4</b>
<b>4、 Work theory.....</b>	<b>4</b>
<b>5、 Classify and name.....</b>	<b>4</b>
<b>5.1 Classify .....</b>	<b>4</b>
<b>5.2 Name .....</b>	<b>5</b>
<b>6、 Main technical parameters .....</b>	<b>5</b>
<b>7、 Features.....</b>	<b>5</b>
<b>8、 The structure of main machine, control board and accessory.....</b>	<b>6</b>
<b>8.1 The structure of main machine.....</b>	<b>6</b>
<b>8.2 Operation panel .....</b>	<b>7</b>
<b>8.3 Accessory.....</b>	<b>9</b>
<b>9、 Installation and adjustment.....</b>	<b>10</b>
<b>9.1 Installation and its requirements .....</b>	<b>10</b>
<b>9.1.1 Installation requirements.....</b>	<b>10</b>
<b>9.1.2 Install centrifuge .....</b>	<b>11</b>
<b>9.2 Adjust centrifuge .....</b>	<b>11</b>
<b>10、 Operation.....</b>	<b>11</b>
<b>10.1 Check the rotor and tube.....</b>	<b>11</b>
<b>10.2 Install rotor.....</b>	<b>11</b>
<b>10.3 Adding liquid and placing of the centrifugal tube .....</b>	<b>12</b>
<b>10.4 Close the door lid .....</b>	<b>12</b>
<b>10.5 Set program, rotor number, speed, time, acceleration and deceleration profiles .....</b>	<b>12</b>
<b>10.6 Start and stop .....</b>	<b>15</b>
<b>10.7 Take out the centrifugal tube .....</b>	<b>15</b>
<b>10.8 Uninstall the rotor .....</b>	<b>15</b>
<b>10.9 Power off .....</b>	<b>15</b>
<b>11、 Service and maintenance .....</b>	<b>16</b>
<b>12、 Common trouble and trouble shooting.....</b>	<b>17</b>
<b>12.1 Common error code.....</b>	<b>17</b>
<b>12.2 Common trouble shooting.....</b>	<b>18</b>
<b>13、 Transportation and storage.....</b>	<b>19</b>
<b>13.1 Transportation .....</b>	<b>19</b>
<b>13.2 Storage .....</b>	<b>19</b>
<b>Attached: Warranty, Packing list and Qualified certificate</b>	

## **1、 Attention for safety**

 **Attention for safety** clarifies the requirements of safe operation in the instruction manual. Please carefully read it before installation, operation, maintenance and repairing. Understanding the warning and correct operation can avoid the personal injury and the damage of centrifuge.

### **1.1 Attention for installation and maintenance**

- The rotor accessory and package may be placed in the centrifugal chamber. You should open the door lid for checking when installing.
- In the machine maintenance process, the parts that need remove cover may cause electrical shock or personal injury. Ensure that the power has been cut off and the power line has been removed from the socket, and qualified staff manipulates it.
- The replaced part must be consistent with the requirements of this centrifuge.

### **1.2 Attention for electric system**

- To reduce the risk of electric shock, the centrifuge adopts the plug with three points which must connect with the socket with ground lead.
- Make sure if the wall socket is connect with the ground wire. The voltage of power supply must accord with the voltage of centrifuge.
- Don't use the power adapter from three holes to two holes.
- It is forbidden to use the expanding socket with two lines or all-purpose power adaptor without ground wire.
- Don't put container with liquid on the centrifuge or around the centrifuge. If the container is knocked over, the liquid will infiltrate into centrifuge and damage the electrical or mechanical parts.

### **1.3 Attention for fireproofing**

- Please use the overload fuse with same model and specification.
- The centrifuge is not designed for the flammable and explosive matters. You cannot make centrifugation for the matters (chloroform, acetaldehyde), and cannot put the matters in the centrifuge or store them around centrifuge within 30cm.

#### **1.4 Attention for safe operation**



- Please use the rotor and accessories which are designed for this centrifuge
- Make sure if the centrifugal chamber is cleaned before operation.
- Make sure if the screw (nut) of the rotor in the centrifugal chamber has been screwed down.
- Not exceed its max speed of rotor during operation.
- Don't decelerate rotor speed or stop it by hand.
- Don't hold or move centrifuge when rotor is rotating.
- If the glass test tube is cracked in centrifuge chamber, please carefully check and clean the gasket and centrifugal chamber because the glass fragment may have inserted into their surface.
- Don't open the door lid of centrifuge in the running status.
- The distance between centrifuge and other objects must be kept 30cm during operation. You should not stand around centrifuge within 30cm unless adjusting it. Anything is not allowed to enter into centrifuge during operation.

#### **1.5 Attention for safety in chemistry and biology**

- The routine manipulation may include all kinds of liquid and test sample which may be the disease-causing and poisonous matters. The centrifuge can not be manipulated with the matters unless you have taken the protection measures.
- Please pay attention to the liquid explanation in original container before operation.
- These solutions must be controlled carefully, because they may be contagious. Must manipulate them strictly according to manipulating procedure and method specified in lab.
- You should follow the environment security and protection requirements when destroying the discarded liquid.

**Users have the responsibility to clean and sterilize centrifuge and accessory if you need maintenance service from our company.**

## 2、 Symbol and its meanings

No.	Symbol	GB No.	Meanings
1	~	4706.1	Alternating current
2		5465.2	Power on(general supply)
3	○	5465.2	Power off (general supply)
4		4728.2	Protective earthing(ground)
5		4793	Warning! (see attachment paper)

Form 1

## 3、 Application and scope

L-550 tabletop low speed centrifuge makes use of centrifugal settling to separate, purify and condense the granule. It can be widely used in the fields of clinical medicine, biochemistry, genetic engineering and radioimmunology. It is ideal equipment for scientific research institute and hospitals.

## 4、 Working Theory

Centrifuge makes use of the strong RCF that centrifuge rotates with high speed in order to accelerate the settling speed of the granule in the liquid, and separate, condense and purify the matters with different settling coefficient and density.

## 5、 Classify and Name

### 5.1 Classify

- It belongs to Class 1 of medical laboratory equipment according to the management of “The Classified Catalogue of Medical Devices”.
- It belongs to Class 1 of ordinary equipment with protective grounding according to the protection against electric shock.
- It belongs to tabletop centrifuge according to the structure.
- It belongs to low speed centrifuge according to the speed.

## 5.2 Name

low speed                               max.speed identification No., unit is 10r/min

L550 tabletop low speed centrifuge whose Max.speed is 5500×10r/min.

## 6、 Main technical parameters

Model	L550
Max.speed	5500r/min
Max.RCF	5310×g
Speed controlling accuracy	±30r/min
Time setting range	0~99min
The shortest Acc and Dec time	28s/30s
Power supply	~220V 50/60Hz 10A
Noise	<65dB (A)
Dimension	470mm×560mm×380mm (W×D×H)
Package dimension	550mm×730mm×420mm (W×D×H)
Weight	G.W.:45Kg N.W.:42Kg
Environment requirements	Temperature: 10℃~35℃, Relative humidity≤85%

Form 2

## 7、 Features

- Microprocessor control
- Touch panel and LCD display
- The speed is controlled by PWM with the function of high accuracy and fast Acc/Dec.
- It is controlled by AC frequency conversion motor with low-noise and vibration. It runs without carbon dust pollution, which can meet the requirements of lab.
- RCF value can be calculated automatically.
- Adopt special shock isolator for ideal effect of vibration damping, with the function of automatic balance.

· Electronic lock door for safe operation. The centrifuge will reluctant to work if the lid isn't closed properly; the centrifuge will stop automatically while the lid is open abnormally during a run.

## 8、 The structure of main machine, control board and accessories

### 8.1 The structure of main machine

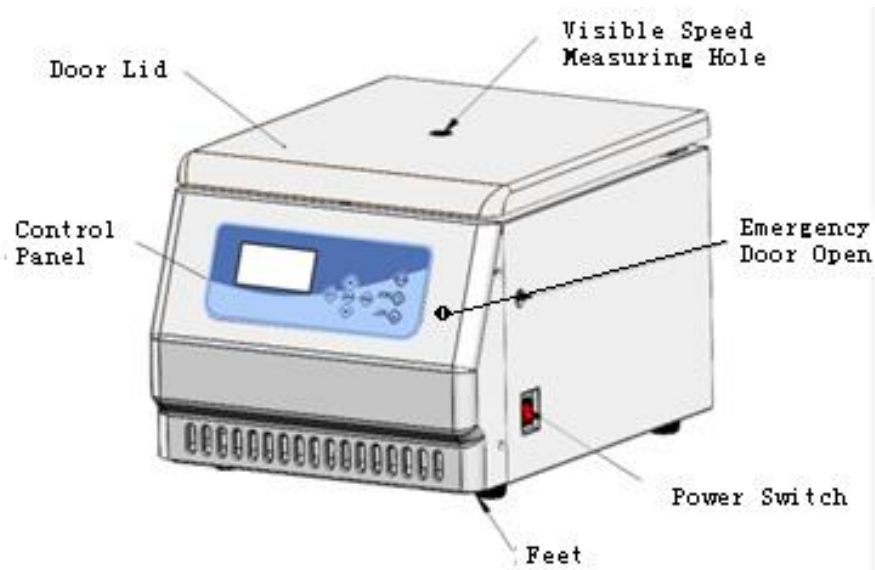

Figure 1

L550 tabletop low speed centrifuge is composed of the main machine and accessories. The main machine is composed of outer casing, centrifugal chamber, drive system, control system and the part of manipulation display. The rotor and centrifugal tube(bottle) belong to accessory(provide according to contract).

## 8.2 Operation Panel

LCD display window:



Figure 2

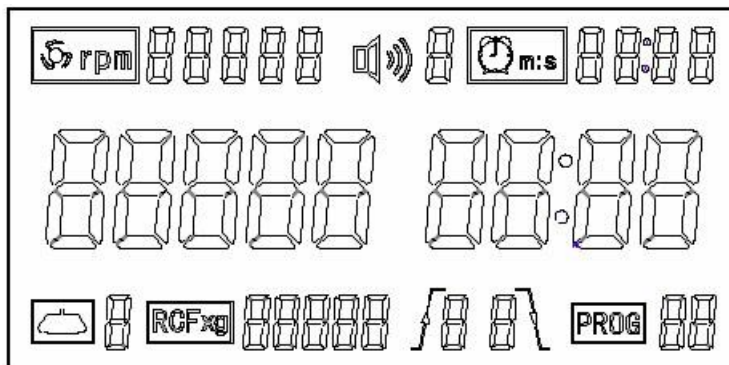

Display Screen



**Rotor:** Display setup or current running rotor No.;



**Program :** Display running program No.;



**Speed:** Speed display window, the front figure is the setup speed and the next figure is actual running speed (unit: rpm);



**Time:** Time display window, the front figure is the setup time and the next figure is the balance of running time (unit: minute and second);



 **RCF:** RCF display window at real time;

 **Acceleration:** Display setup acceleration profile;

 **Deceleration:** Display setup deceleration profile;

: Error/Default display window. Display the default message while the trouble/default occurs during instrument operation.

### **Key function:**

**SET:** Setting key. Set program No., rotor No., speed, time, acceleration and deceleration profiles by press this key once or several times until the selected item flashing.

**PROG:** Program key. Select program preferences; revise and save program preferences.

**▲:** Increase key. When you set rotor number, speed, Acc/Dec and time, press “▲” to increase the setting parameter value.

**▼:** Decrease key. When you set rotor number, speed, Acc/Dec and time, press “▼” to decrease the setting parameter value.

**ENTER:** Press [ENTER] to confirm and store the setup values of rotor No., Acc/Dec. profiles, speed and time.

**START:** Press [START] to begin centrifugation after setting and confirming the parameters or repeating the setup parameters last time, and the start indicator light on.

**STOP:** The key to stop centrifugation and open the door lid. When the centrifuge is working (time isn't counted down to “0”), you can stop it by manual and the stop indicator light on. When the centrifuge is in the state of standby, press it to open the door lid.

### **The function of indicator lights:**

**[START] indicator light:** The [START] indicator light is on, which means that the centrifuge has started and in the running status.

**[STOP] indicator light:** The [STOP] indicator light is on which means [STOP]

is pressed or the work time is counted down to “0”. The centrifuge is slowing down for stopping or has stopped.

### 8.3 Accessory

#### Rotor for L550 Form 3

Rotor Number		Max speed (r/min)	Capacity (ml)	Max RCF (×g)
No.1 Angle Rotor		5500	12×10ml	5310
No.2	Swing rotor	4000	4×500ml	3040
	Adapter	4000	4×250ml	3040
			12×50ml	
			28×20ml	
			36×15ml	
			76×5ml	
	Swing bucket rotor	4000	Four rectangular buckets	3040
	Adapter	4000	4×28×5ml	3040
			4×25×1.5ml	
			4×20×10ml	
			4×10×15ml	
			4×4×50ml	
	Swing rotor	4000	148×5ml	3040
			96×7ml	
Micro plate rotor	4000	4×2×96well	3040	
No.3 Micro plate rotor		4000	2×2×96well	2200
No.4 Swing Rotor		5000	4×50ml	4390
			4×100ml	
No.5 Swing Rotor		4200	8×50ml	3100
	bracket	4200	8×100ml	3100
	bracket		32×15/10/7ml	
	bracket		48×7ml	
	bracket		64×5ml/7ml	

## 9、 Installation and adjustment

### 9.1 Instrument installation and its requirements:

#### 9.1.1 Installation requirements:

 Warning: Don't install centrifuge in the place with flammable and explosive matters. The flammable and explosive gas comes into the running centrifuge, which may lead to fires.

- The centrifuge should be installed on the flat and solid platform.
- The large free space should be kept around the two sides and back of centrifuge for heat dissipation for ventilation.
- It is prohibited to put lab equipment with large heating production and strong vibration around centrifuge.
- The working environment temperature is 10°C to 35°C, and the relative humidity is no more than  $\leq 85\%$ .
- The requirement of power supply: 220V 50/60Hz 10A

#### 9.1.2 Install centrifuge

- Open the outer package, carefully take out the centrifuge with foam package, then put it on the even platform and take off the foam package. The four rubber feet of centrifuge should touch with platform evenly.
- Pull the string for door opening on the bottom of centrifuge outward, then uplift the door lid until it is hold by gas spring.
  - Clear the centrifugal chamber.
- Check the main machine, accessory, attached tools and documents according to the packing list.
- You should confirm that the voltage of the power supply should be consistent with the voltage the centrifuge requires. (Check the marking beside the electric outlet on centrifuge back, and the instrument's power requirement is AC 220V 50/60Hz with single phase and three wires.) Connect the power cord(three wires and 10A) to the electric outlet on centrifuge back first, then put the plug on the other end into the external electric supply socket. Press one side marked “I” on the switch to power

on.

- If there are any electronic problems, it should be repaired by the professional technicians.

## 9.2 Centrifuge adjustment



Warning: It is forbidden to start before the centrifuge chamber is not cleaned. Otherwise, the centrifuge may be damaged.

According to the operation steps of Chapter 10, first run with low speed, and gradually accelerate to the max.speed. If no abnormal phenomenon happens, you have succeeded in adjustment.

## 10、 Operation

**10.1 Check the rotor and tube:** You should carefully check the rotor, tube or test bottle before operation. It is forbidden to use the cracked and damaged rotor, tube or test bottle. Otherwise, all damages should be borne by user.

**10.2 Install Rotor:** Rotor installation steps:

- (1). Take down the clamping screw components from the motor shaft.
- (2). Clean up the internal hole of the rotor yoke and the motor shaft.
- (3). Put the rotor yoke(cone down) on the motor shaft.
- (4). Screw tightly the clamping screw components on the rotor shaft by T-shape spanner.
- (5). If accidentally disassemble the clamping screw components, please assemble it again according to above figure. Please pay attention to the placing direction of the two disc spacers.

**Note: Make sure that the rotor is installed properly, otherwise there will be a safety accident**

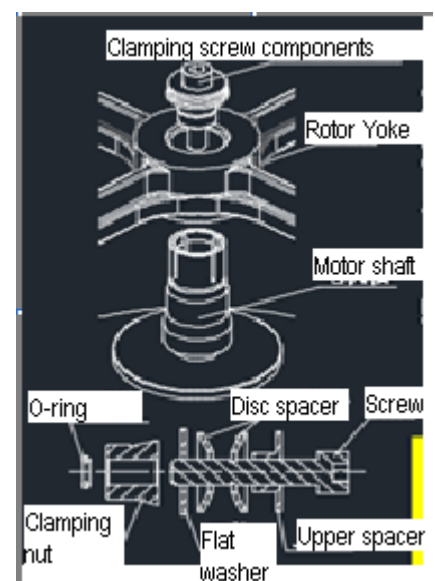

**10.3 Adding liquid and placing the centrifugal tube:** Put centrifugal tubes with adding liquid into the centrifugal tube of rotor and tubes should be placed symmetrically in even number. Otherwise, there will be vibration and noise because of imbalance.

**10.4 Close the door lid:** Press down the door lid until you hear “clicking” sound which means the door lid pin enter into the hook. Then lift the door lid by hand to check whether it is closed properly. If the door lid can not be opened, it means it is closed properly. If press the [START] key and centrifuge cannot run, the buzzer will tweet and LCD display window shows [D/M5] error code which means the door lid is not closed properly. Press [STOP] key to clear the error show, and close the door lid properly again.

**10.5 Set program, rotor number, speed, time, Acc and Dec profiles:**

After power on the machine, the system displays the setup value in last operation which stored before it stopped. Then press [START] to run. If require modifying the setup value, please operate according to the following steps:

1) Elect, store and modify the preset program.

a. **Program storing:** In the stopping status, press “PROG” once and the “PROG” value flashes (  character do not flash ) , then press[▲]/[▼] to select the preset program(preset programs are 1 to 25, total 25 programs). At last must press“ENTER” to confirm the current settings. Otherwise, it will automatically cancel the set up after 3 seconds.

b. **Program using:** In the stopping status, press “PROG” twice and  character and digital value will flash simultaneously, then press[▲]/[▼] to select the stored program(preset programs are 1 to 25, total 25 programs). At last must press“ENTER” to confirm the program selection. Otherwise, it will automatically cancel the setup after 3 seconds.

c. **Program modifying:** Operate according to the following 9.5.2~9.5.6 steps:

press“ENTER” to confirm and the current program will automatically be stored as 0. If press“PROG” in the status of parameters being modified, the “PROG” value flashes (  character do not flash ) and then press[▲]/[▼] to select the stored program(preset programs are 1to 25, total 25 programs). At last must press“ENTER” to confirm.The parameters in current program number will automatically be covered(modified) by parameters in “PROG0”.

2) **Rotor number:** Press the “SET” key until “” display window flashing, and then you can set rotor number; press “▲” or “▼”to select the installed rotor number. Press “ENTER” to keep current setting at last, otherwise it will automatically cancel the setup after 3 seconds. It is prohibited to modify rotor number during a run.



**Warning:** The rotor type should be set according as the installed one.  
Wrong setting will make the rotor overspeed and lead to accident.

3) **Speed:** Press the “SET” key until “” display window flashing, then you can set speed value; and then press “▲” or “▼”to set speed for this centrifugation. Press “ENTER” to keep current setting at last, otherwise it will automatically cancel the setup after 3 seconds.

4) **Time:** Press the “SET” key until “” display window flashing, then you can set time(Time range: 1min59s~99min59s); and then press “▲” or “▼”to set time for this centrifugation(set minutes while “min” flashes; set seconds while “s” flashes). Press “ENTER” to keep current setting at last, otherwise it will automatically cancel the setup after 3 seconds.

5) **Acc profiles:** Press the “SET” key until “” display window flashing, then you can set Acc profiles; and then press “▲” or “▼”to set Acc profiles for this centrifugation. There is 1~9 Acc profiles, and the acc time would be shorter while the setting figure is bigger. We choose 5 usually. Press “ENTER” to keep current setting at last, otherwise it will automatically cancel the setup after 3 seconds.

6) **Dec profiles:** Press the “SET” key until “” display window flashing, then you can set Dec profiles; and then press “▲” or “▼” to set Dec profiles for this centrifugation. There is 1~9 Dec profiles, and the stopping time would be shorter while the setting figure is bigger. We choose 5 usually. Press “ENTER” to keep current setting at last, otherwise it will automatically cancel the setup after 3 seconds.

7) Above steps can be set continuously, and press [ENTER] to confirm at last.

After confirming the setting value of rotor number, speed and time etc., press [START] to run the centrifuge. If “ 8” error code shows which means maloperation, you should reset speed/No. parameters.

### 10.6 Start and stop

- (1)、 **Start:** Press [START] to start centrifuge and the [START] indicator light is on.
- (2)、 **Automatic stop:** When time is counted down to “0”, the centrifuge automatically slows down and stops running. When the speed is 0 r/min, the buzzer will tweet and the [STOP] indicator light is on.
- (3)、 **Stop by manual:** In the running status (the working time isn’t counted down to “0”), press [STOP] to slow down and stop running. The buzzer will not tweet, and the [STOP] indicator light is on.

 **Attention:** When the centrifuge is running, while the Power is suddenly off , it will cause the electrical lock can’t work, so the Lid can’t open. You must wait the speed stop to 0 r/min, then open the lid by Emergency way (Poke into the Emergency lock hole on the front panel by using the inner hexagon spanner which along with the centrifuge Tools, aim at the Inner six angle Lock hole of the centrifuge, clockwise rotate to open the Lid).

**10.7 Take out the centrifugal tube:** When the rotor stops rotating, press the [STOP] key to open the door lid. Then press the switch with the mark“O” to cut off the power. Open the door lid and take out the centrifugal tubes.

**10.8 Uninstall the rotor:** When replacing the rotor, you should uninstall the used

rotor (unscrewing the bolt with screwdriver and take out the rotor after removing spacer.)

⚠ Don't hold up or move the centrifuge during operation.

⚠ Don't open the door lid when rotor is rotating.

**10.9 Power off:** Turn off power and unplug power cable after finishing work.

## 11、 Service and maintenance

· Please wipe up the rotor with neutral cleaning mixture after taking out for avoiding corrosion and then stock it at dry and ventilated place. Central hole in rotor should be smeared some lubricating oil for protection.

· All action on rotor should be soft, and rotor should be taken out vertically for protecting the shaft.

· Please wipe up the water in centrifuge chamber if it is leaving unused for long time. Some lubricating oil should be smeared on drive shaft for protection.

· Replace fuse

(1) Cut off the power, and unplug the plug the power cord connected with the external electric supply socket. Then draw another end of the power cord connected with the centrifuge.

(2) There is a fuse case equipped on the under part of electric outlet on instrument back. (See figure 3) There is a marking for fuse symbol, and find the V-shape slot on fuse case. (See figure 4) Pull out the fuse case with slotted point screw driver into the V-shape slot.

(3) Take out the damaged fuse and replace it. The model of fuse of the centrifuge is BGXP 5×20 、 250V 10A.

(4) Put the fuse case into electric outlet.



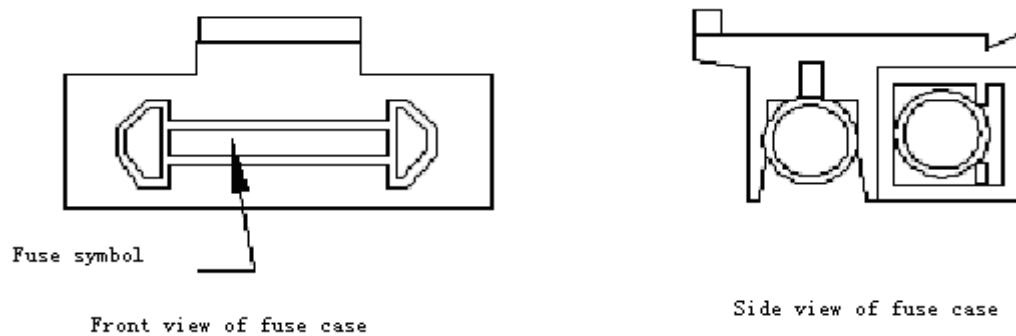

Figure 3

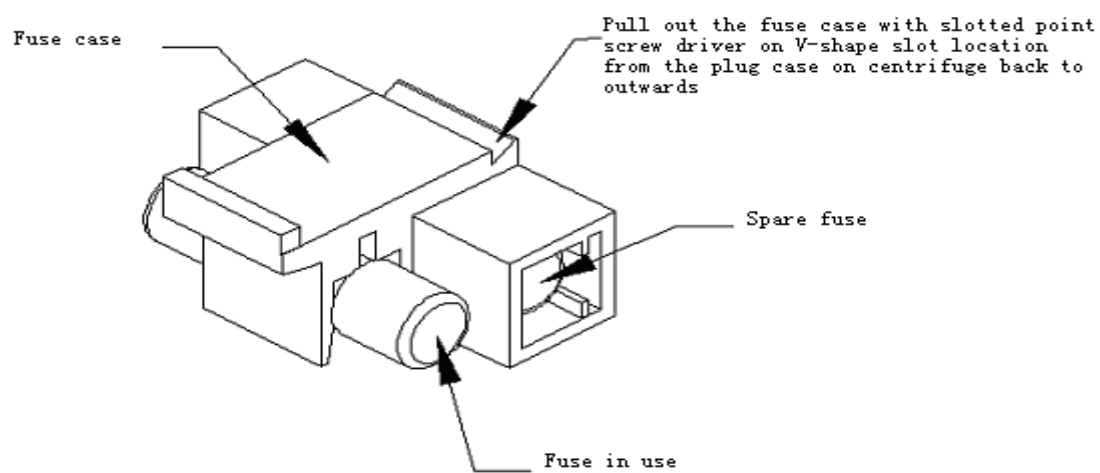

Figure 4

## 12、 The common trouble and trouble shooting

### 12.1 Common error code:

Error code	Description	Reasons	Solution
E6	Overspeed	Check and reset speed, rotor number, Acc and Dec value	Reset parameters
		Inverter parameters are not set properly.	Reset parameters
E5	Door lid protection	The door lid isn't closed when pressing [START].	Close door lid properly
		The installed sensitive switch of door lid is not in place or damaged.	Check and replace
	Door open during run	The sensitive switch of door lid detecting triggers the protection function during centrifugation.	Close door lid properly
E7	Motor does not run or runs without speed	Motor runs without speed; The speed-detecting signal is unreliable or the speed sensor is damaged.	Check and replace
		Motor does not run, and the shaft is blocked.	Replace motor
		Inverter parameters are not set wrongly.	Check and replace
E8	Wrong setup and maloperation	Set or operate wrongly.	Reset

## 12.2 Common trouble shooting:

Trouble	Cause	Removal
The display window is not working.	No rated power supply; power switch to power control board is short-circuit (rosin joint); the transformer on power control board is damaged or not connecting properly.	Check power supply
Miss strokes or content on display window	Connectors of LCD board is not plugged-in properly or LCD screen is damaged	Check and Plug in properly
Air switch jumps off	Electrolytic capacitor is breakdown or power control board is short-circuited.	Replace
The rotor doesn't run when Start key is pressed	Check the error code(default message) showed on the display window.	Deal with correspondently
Dithering or abnormal noise	Samples for centrifugation are not arranged properly (symmetrically and in even).	Check and rearrange
	The rotor is not installed properly or loosen	Check and reinstall
The door lid doesn't open when Start key is pressed	The connectors are loosen or not connected properly(rosin joint); Electromagnet is damaged	Check and replace
Centrifuge shakes largely	Centrifuge is not placed on level or Samples for centrifugation are not arranged symmetrically	Adjust level and placed symmetrically

If the centrifuge still can not work after removing the above several troubles, please connect with our company or service stations designated by our company.

## **13、 Transportation and storage**

### **13.1 Transportation**

- You should use the wooden case and carton during long-distance transportation. Put centrifuge with dust cap into the case, and fill with foam or plastic shock absorption materials. It is forbidden to be hit, inverted, rolled and soaked by rain and snow.
- You can directly move the centrifuge in room, but avoid big vibration, hitting and inversion.

### **13.2 Storage**

- If it is leaving unused for long time, you should open the door lid and store it in ventilated, dry and clean room where is no corrosive, flammable and explosive matters.
- As the technology continuously renews, please consult us if there is something unconformable with this instruction manual.

# Warranty

Respected customers,

Thank you for purchase of our company's products. To protect your legal rights and avoid your worries, we provide warranty service for one year with the main machines. If it is broken under warranty with inartificial reason, we will supply free maintenance service. The customer needs to pay an amount of money if the product has exceeded the warranty period. We will not supply free maintenance if any following matter is happened:

- Exceed of the warranty period or without the warranty card.
- The trouble is caused by wrong installation, operation and maintenance.
- The trouble is caused by the unauthorized uninstalling and repairing by our company.
- The trouble is caused by using the rotor not equipped with this centrifuge.
- The trouble is caused by war, natural disasters or other irresistible factors.

# Packing List

Item	No	Name	Quantity	Unit	Remark	Check
Main machine	1	L550(LCD)	1	set		
	2	Swing rotor 4x500ml	1	set		
Option of rotor and accessories						
Attached tool	1	Fuse BGXP 5×20 (inside power socket)	5	pc	250V 10A	
	2	Power cord	1	pc		
	3	T-shaped inner hexagon spanner	1	pc		
Attached file	1	Packing List	1	copy		
	2	Instruction Manual	1	copy		
	3	Qualified Certificate	1	copy		

Checker:

Date:

# Quality Certificate

Product Name: Tabletop Low Speed Centrifuge

Product Model: L550

Serial No.: \_\_\_\_\_

This product is tested and qualified for delivery.

Checker:

Date: